

The Model 5600 is a spring-loaded, self-operated pressure regulator, available in 1" and 2" sizes and built to withstand the most difficult processes and environments. It is offered in both low-pressure and high-pressure constructions, and is designed for inlet pressures up to 1500 psig and outlet pressures from 3 to 500 psig. The Model 5600 regulator is well suited for high pressure, high capacity applications (see Specifications).

Regulator Features:

- Easy Maintenance
- Variety of Flow Capacities
- Rugged Construction
- Excellent Control at Low Pressure Settings
- NACE Compliance
- Flanged Connections Option



Regulator Specifications:

End Connections

1" NPT Female
2" NPT Female

Outlet Pressure Ranges

See Table 1

Maximum Inlet and Differential Pressure

See Table 2

Operating Temperature Limits

-20 to 150°F (-29 to +65°C)

Port Diameters

1/8"
3/16"
1/4"
3/8"
1/2"

Construction Materials

Body:	Steel or ductile iron
Inlet Adapter:	Steel
Diaphragm Adapter:	Steel or ductile iron
Spring Case:	Steel or ductile iron
Orifice:	Brass or 302 SST
Valve Disk and Holder:	Brass holder w/ Viton disk Brass holder w/ Nylon disk Brass holder w/ TFE disk 302 SST holder w/ Viton disk 302 SST holder w/ Nylon disk 302 SST holder w/ TFE disk
Valve Carrier:	Brass or 302 SST
Diaphragm:	Buna-N or Viton (embedded nylon fabric)
Lever:	Steel
Diaphragm Connector Head:	Brass or 302 SST

Flow Capacities

Low Pressure Regulator:	See Table 3
High Pressure Regulator:	See Table 4



CAUTION - Model 5600 regulators have an outlet pressure rating that is lower than the inlet pressure rating. Consequently, overpressure protection is required if the actual inlet pressure can exceed the regulator's

outlet pressure rating. To avoid overpressure, provide an appropriate overpressure protection device to ensure that none of the limits listed in the Specifications will be exceeded.

Table 1. Outlet Pressure Ranges

	Outlet Pressure Range, psig	Maximum Outlet Pressure Over Pressure Setting ³ , psig	Maximum Emergency Outlet Pressure, psig
Low Pressure	3 to 10	20	45
	8 to 20		
	17 to 30	20 ¹	
	27 to 40	Note 1	
High Pressure	27 to 50	200	550
	46 to 95		
	90 to 150		
	150 to 200		
	200 to 275		
	275 to 500		

Table 2. Maximum Inlet and Differential Pressures

Port Dia.	Maximum Allowable Inlet Pressure, PSIG ¹	Maximum Allowable Pressure Drop, PSID	
		TFE or Nylon Disk	Viton Disk
3/16" or 1/8"	1500	1500	200
1/4"	1500	1000	
3/8"	1000	500	

1. This applies to outlet pressure settings below 25 psig only. For pressure setting above 25 psig, outlet pressure is limited to 45 psig, the maximum emergency outlet pressure.
2. This applies to outlet pressure settings below 350 psig only. For pressure setting above 350 psig, outlet pressure is limited to 550 psig, the maximum emergency outlet pressure.
3. Internal parts of the regulator may be damaged if the outlet pressure exceeds the pressure setting beyond the amounts shown.

1. The sum of the outlet pressure setting and the maximum allowable pressure drop determines the maximum allowable inlet pressure for a given installation. For example, with a 1/2" port diameter (maximum pressure drop of 250 psi) and a 400 psig outlet pressure setting, the maximum inlet pressure is 650 psig (250 psi plus 400 psig).

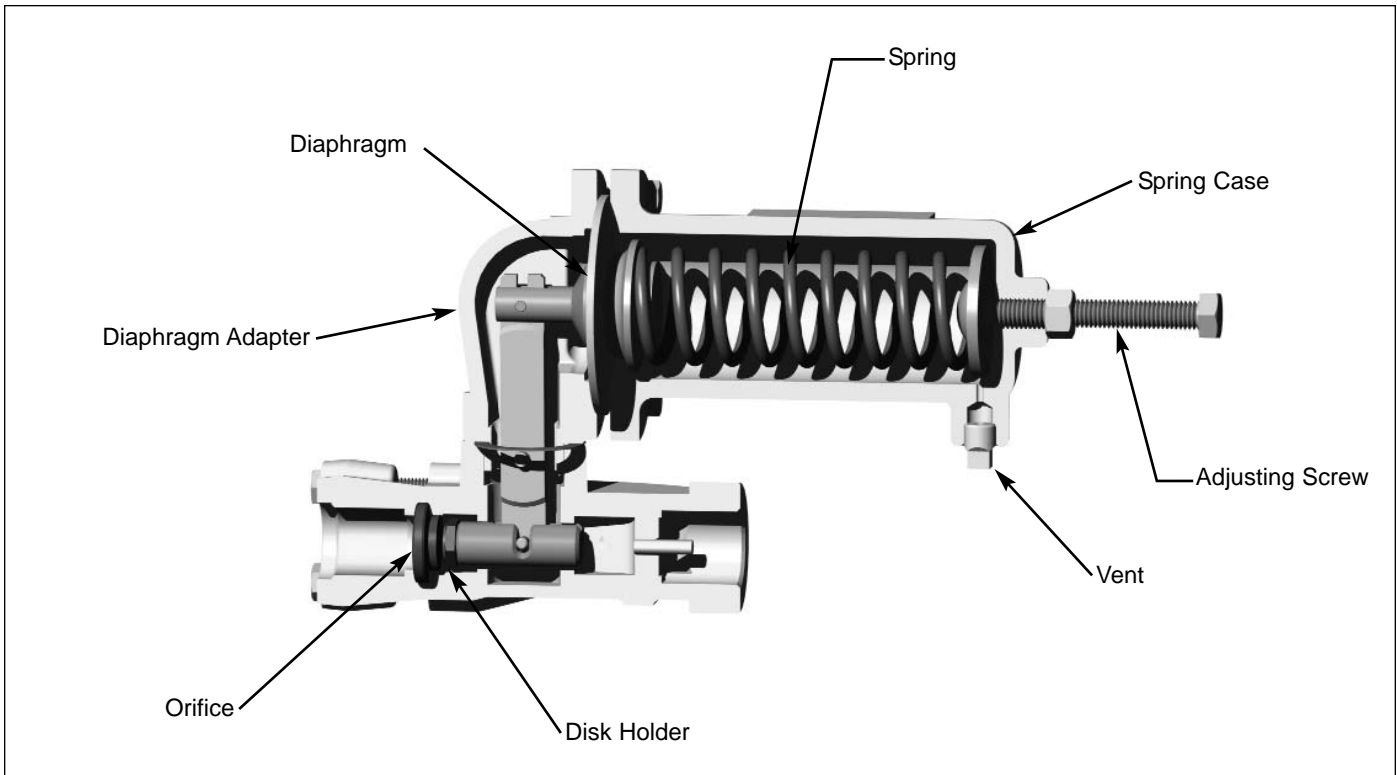

Table 3. Low Pressure Regulator Flow Capacities (scfh of 0.6 Specific Gravity Gas; based on 20% Droop)

.01 Inlet Pressure (PSIG)	Outlet Pressure (PSIG)	Port Diameter									
		1" NPT					2" NPT				
		1/8"	3/16"	1/4"	3/8"	1/2"	1/8"	3/16"	1/4"	3/8"	1/2"
10	(3 to 10 psig or 8 to 20 psig spring)	200	510	990	1700	2200	290	830	1300	3300	5900
20		400	770	1200	2000	2700	500	1200	2100	4800	9100
30		600	1100	1500	2200	3300	760	1600	2700	7000	11,000
50		950	1500	2100	2800	4100	1100	2200	3900	9800	17,000
60		1100	1750	2400	3000	4200	1250	2700	4500	11,100	19,500
75		1300	2100	2700	3400	4400	1500	3300	5400	13,000	23,000
100		1700	2400	2900	4000	4900	1900	4300	7000	17,000	30,000
150		2200	3000	3500	4600	5800	2800	6200	10,000	25,000	43,000
200		3000	3400	4200	5100	6100	3700	8200	13,000	32,000	57,000
250		3500	3800	4300	5900	6800	4500	10,000	17,000	38,000	70,000
400		3700	3900	4500	6400	----	7200	1600	28,000	64,000	----
500		4100	4300	4700	7400	----	9100	19,000	35,000	79,000	----
600		4300	4600	5000	----	----	10,000	24,000	42,000	----	----
1000		4600	4900	5600	----	----	18,000	39,000	69,000	----	----
1500		5000	5400	----	----	----	22,000	60,000	----	----	----
20	(3 to 10 psig or 8 to 20 psig spring)	500	1200	1800	4100	4900	560	1300	2200	5100	9000
30		700	1400	2800	4200	5300	770	1500	3000	7000	11,000
50		1000	2300	4100	5100	6200	1100	2400	4300	9800	17,000
60		1150	2700	4200	5500	6500	1250	2800	5000	11,100	19,500
75		1400	3200	4400	6000	6800	1500	3400	5900	13,000	23,000
100		1600	3800	5000	6400	7300	1900	4400	7600	17,000	30,000
150		2400	4800	6200	7300	7900	2800	6200	11,000	25,000	43,000
200		3300	5800	6900	7700	8200	3700	8100	14,000	33,000	57,000
250		4000	5900	7300	8600	8700	4400	10,000	17,000	41,000	70,000
400		5400	6900	7600	9000	----	7200	16,000	28,000	62,000	----
500		6000	7100	7900	9700	----	8900	19,000	35,000	76,000	----
600		6500	7300	8200	----	----	10,000	23,000	42,000	----	----
1000		7200	7700	8400	----	----	18,000	40,000	72,000	----	----
1500		7400	8400	----	----	----	27,000	60,000	----	----	----

- Continued -

Table 3 (continued) Low Pressure Regulator Flow Capacities (scfh of 0.6 Specific Gravity Gas; based on 20% Droop)

Inlet Pressure (PSIG)	Outlet Pressure (PSIG)	Port Diameter									
		1" NPT					2" NPT				
		1/8"	3/16"	1/4"	3/8"	1/2"	1/8"	3/16"	1/4"	3/8"	1/2"
20	15 (8 to 20 psig spring)	470	1000	1700	3300	4900	520	1100	1800	3500	5700
30		600	1500	2500	4600	5200	740	1600	2800	5900	10,000
50		1000	2300	3800	5500	5700	1100	2400	4300	9800	16,000
60		1150	2700	4300	6100	6800	1250	2800	5000	11,100	18,000
75		1400	3300	5100	7000	8500	1500	3400	6000	13,000	23,000
100		1900	4300	6200	7600	9600	1900	4400	7800	17,000	30,000
150		2700	6100	7400	8000	9900	2800	6400	11,000	25,000	43,000
200		3600	7500	8500	9600	5800	3700	8300	14,000	30,000	57,000
265		4700	8400	9100	10,000	10,000	4800	10,000	19,000	39,000	74,000
400		7100	8700	10,000	11,000	11,000	7200	16,000	29,000	64,000	----
515		8300	8800	10,500	12,000	----	9200	20,000	37,000	82,000	----
600		8600	9600	10,800	----	----	11,000	23,000	42,000	----	----
1015		9600	10,000	11,000	----	----	18,000	40,000	71,000	----	----
1500		10,000	11,000	----	----	----	27,000	60,000	----	----	----
30		20 (8 to 20 psig or 17 to 30 psig spring)	600	1500	2500	4600	6800	700	1600	2600	5200
40	800		2000	3400	5700	8100	900	2100	3500	7500	12,000
50	1000		2300	4200	6800	9000	1100	2400	4300	9400	15,000
60	1150		2700	4900	7500	9800	1250	2800	5100	11,000	18,000
75	1400		3300	5900	8500	10,000	1500	3400	6100	13,000	23,000
100	1800		4100	7400	9500	11,000	1900	4300	7800	17,000	29,000
150	2700		6100	9200	11,000	12,000	2800	6300	11,000	23,000	42,000
200	3600		8000	10,000	12,000	13,000	3700	8200	14,000	32,000	59,000
270	4500		9800	11,000	13,000	14,000	4900	10,000	19,000	39,000	75,000
400	7200		10,000	13,000	14,000	----	7300	16,000	28,000	63,000	----
520	8800		11,000	13,500	15,000	----	9500	20,000	37,000	82,000	----
600	10,000		12,000	13,800	----	----	11,000	24,000	43,000	----	----
1020	11,000		12,300	15,000	----	----	18,000	40,000	73,000	----	----
1500	12,000		13,000	----	----	----	27,000	60,000	----	----	----

- Continued -

Table 3 (continued) Low Pressure Regulator Flow Capacities (scfh of 0.6 Specific Gravity Gas; based on 20% Droop)

Inlet Pressure (PSIG)	Outlet Pressure (PSIG)	Port Diameter									
		1" NPT					2" NPT				
		1/8"	3/16"	1/4"	3/8"	1/2"	1/8"	3/16"	1/4"	3/8"	1/2"
40	30 (17 to 30 or 27 to 40 psig spring)	820	1700	2700	5100	7600	860	1800	2900	5300	8500
50		900	2200	3600	6400	8700	1000	2300	3800	7300	11,000
60		1100	2600	4400	7500	9800	1200	2700	4700	8900	14,000
75		1400	3300	5400	8800	11,000	1500	3400	5800	11,000	18,000
100		1700	4100	6800	10,000	12,000	1800	4200	7800	16,000	28,000
150		2600	6000	9100	13,000	14,000	2700	6100	11,000	20,000	44,000
200		3500	8000	11,000	14,000	16,000	3600	8100	14,000	24,000	58,000
280		4900	10,500	13,000	15,000	17,000	5000	11,000	20,000	46,000	80,000
400		6900	13,000	15,000	17,000	----	7000	16,000	28,000	64,000	----
530		9400	14,500	15,800	19,000	----	9500	20,000	37,000	86,000	----
600	9700	15,000	16,000	----	----	10,000	23,000	42,000	----	----	
1030	16,000	18,000	18,000	----	----	19,000	41,000	73,000	----	----	
1500	16,400	18,500	----	----	----	27,000	61,000	----	----	----	
50	40 (27 to 40 psig spring)	950	1800	3200	5500	8900	1000	2100	3400	5900	9900
60		1100	2300	4100	7600	10,000	1200	2600	4300	7900	12,000
75		1400	3000	5300	9300	12,000	1500	3400	5600	10,000	16,000
100		1800	4100	7000	11,000	14,000	1900	4300	7200	13,000	24,000
150		2700	6000	9500	14,000	17,000	2800	6200	10,000	22,000	39,000
200		3500	7800	12,000	17,000	19,000	3600	8200	14,000	30,000	56,000
290		5100	10,000	15,000	19,000	21,000	5200	11,000	20,000	46,000	81,000
400		7100	15,000	18,000	21,000	----	7200	16,000	28,000	63,000	----
540		9500	17,000	19,000	22,000	----	9600	21,000	38,000	86,000	----
600		9800	18,000	21,000	----	----	10,000	23,000	42,000	----	----
1040	17,500	20,000	23,000	----	----	18,000	41,000	73,000	----	----	
1500	20,000	22,000	----	----	----	27,000	61,000	----	----	----	

Table 4. High Pressure Regulator Flow Capacities (scfh of 0.6 Specific Gravity Gas; based on 20% Droop)

Inlet Pressure (PSIG)	Outlet Pressure (PSIG)	Port Diameter										
		1" NPT					2" NPT					
		1/8"	3/16"	1/4"	3/8"	1/2"	1/8"	3/16"	1/4"	3/8"	1/2"	
60	50	900	2000	3100	5200	8100	1000	2100	3200	5300	12,000	
75		1300	2800	3800	7200	10,000	1400	2900	3900	7300	16,000	
100		1700	3500	5700	10,500	13,000	1800	3600	5800	10,000	21,000	
150		2600	5700	8700	13,000	17,000	2700	5800	9000	15,000	36,000	
200		3500	7800	11,000	16,000	19,000	3600	7900	12,000	21,000	55,000	
300		(27 to 50 psig spring)	5300	10,500	14,000	20,000	23,000	5500	11,000	19,000	48,000	83,000
400			6900	13,000	17,000	23,000	----	7000	15,000	27,000	63,000	----
550			9600	16,000	20,000	26,000	----	9700	21,000	38,000	88,000	----
600			9800	17,000	21,000	----	----	10,000	23,000	42,000	----	----
1050			17,000	23,000	27,000	----	----	19,000	42,000	74,000	----	----
1500	19,000		25,000	----	----	----	27,000	60,000	----	----	----	
60	50	800	1500	2400	4300	6400	900	1600	2500	4400	7300	
75		1200	2100	3100	5500	8000	1300	2200	3200	6100	9300	
100		1500	3100	4200	7500	10,000	1600	3400	4300	7600	12,000	
150		2400	4500	6700	11,000	14,000	2500	4600	7100	12,000	19,000	
200		3400	6600	9400	14,000	17,000	3500	6700	9600	16,000	27,000	
300		(46 to 95 psig spring)	5200	8900	11,000	16,000	20,000	5300	10,000	14,000	27,000	51,000
400			6800	11,000	15,000	20,000	----	6900	13,000	21,000	46,000	----
550			9500	13,000	17,000	23,000	----	9600	18,000	29,000	87,000	----
600			9800	14,000	19,000	----	----	10,000	20,000	35,000	----	----
1050			14,000	19,000	22,000	----	----	18,000	41,000	73,000	----	----
1500	18,000		24,000	----	----	----	26,000	59,000	----	----	----	
100	75	1700	3200	5000	8000	13,000	1800	3300	5200	9000	14,000	
125		2200	4300	6700	10,000	15,000	2300	4400	6900	11,000	18,000	
200		3500	7300	10,000	16,000	22,000	3600	7400	11,000	19,000	30,000	
250		4400	9400	13,000	19,000	24,000	4500	9500	14,000	26,000	44,000	
325		5700	11,000	16,000	23,000	27,000	5800	12,000	18,000	36,000	67,000	
400		(46 to 95 psig spring)	7100	14,000	19,000	27,000	----	7200	15,000	24,000	47,000	----
575			9700	18,000	23,000	30,000	----	9800	22,000	37,000	92,000	----
600			9900	19,000	25,000	----	----	10,000	23,000	39,000	----	----
1075			18,000	27,000	32,000	----	----	19,000	42,000	75,000	----	----
1500			23,000	32,000	----	----	----	24,000	60,000	----	----	----

- Continued -

Table 4 (continued). High Pressure Regulator Flow Capacities (scfh of 0.6 Specific Gravity Gas; based on 20% Droop)

Inlet Pressure (PSIG)	Outlet Pressure (PSIG)	Port Diameter									
		1" NPT					2" NPT				
		1/8"	3/16"	1/4"	3/8"	1/2"	1/8"	3/16"	1/4"	3/8"	1/2"
125	100	2000	3600	5500	9200	13,000	2100	3700	5600	9800	15,000
150		2500	4600	6800	11,000	16,000	2600	4900	7400	12,000	18,000
200		3600	6600	9400	13,000	22,000	3700	6900	10,000	17,000	27,000
250		4400	8500	11,000	18,000	26,000	4500	8700	13,000	22,000	34,000
300		5300	9800	14,000	21,000	30,000	5400	10,000	16,000	27,000	44,000
350	(90 to 150 psig spring)	6100	10,000	16,000	25,000	32,000	6300	12,000	19,000	33,000	57,000
400		7000	13,000	18,000	27,000	----	7200	14,000	21,000	39,000	----
600		9500	18,000	23,000	35,000	----	10,000	21,000	34,000	69,000	----
1100		19,500	28,000	35,000	----	----	19,000	43,000	74,000	----	----
1500		25,000	35,000	----	----	----	27,000	59,000	----	----	----
150	125	2400	4600	6700	11,000	17,000	2500	5000	8100	12,000	20,000
200		3500	6800	10,000	15,000	23,000	3600	7400	11,000	19,000	30,000
250		4300	8900	12,000	19,000	29,000	4400	9400	14,000	24,000	39,000
300		5200	10,000	15,000	25,000	34,000	5300	11,000	17,000	31,000	48,000
375		6600	13,000	18,500	28,000	39,000	6600	13,600	21,400	38,300	59,400
400	(90 to 150 psig spring)	7300	14,500	19,000	29,000	----	7300	15,000	24,000	43,000	65,000
500		7900	15,000	25,000	36,000	----	8800	19,000	30,000	59,000	----
625		10,000	22,000	29,000	41,000	----	11,000	24,000	40,000	79,000	----
1125		18,000	33,000	42,000	----	----	19,000	44,000	79,000	----	----
1500		26,000	43,000	----	----	----	27,000	60,000	----	----	----
200	150	3400	6800	10,000	16,000	26,000	3500	7300	11,000	18,000	30,000
250		4400	8800	13,000	20,000	32,000	4500	9500	15,000	26,000	38,000
300		5300	10,000	15,000	24,000	35,000	5400	11,000	19,000	32,000	52,000
400		7100	14,000	22,000	34,000	42,000	7200	15,000	26,000	46,000	77,000
450		7700	17,000	24,000	36,000	----	8100	18,000	29,000	54,000	----
650	150 to 200 psig or 150 to 200 psig spring)	9000	24,000	33,000	49,000	----	10,000	25,000	44,000	88,000	----
800		13,000	29,000	38,000	----	----	14,000	30,000	54,000	----	----
1150		20,000	38,000	49,000	----	----	21,000	46,000	78,000	----	----
1500		26,000	47,000	----	----	----	27,000	60,000	----	----	----

- Continued -

Table 4 (continued). High Pressure Regulator Flow Capacities (scfh of 0.6 Specific Gravity Gas; based on 20% Droop)

Inlet Pressure (PSIG)	Outlet Pressure (PSIG)	Port Diameter									
		1" NPT					2" NPT				
		1/8"	3/16"	1/4"	3/8"	1/2"	1/8"	3/16"	1/4"	3/8"	1/2"
250	(150 to 200 psig or 200 to 275 psig spring)	4200	8300	12,000	20,000	30,000	4300	9100	13000	23,000	42,000
300		5200	10,000	16,000	25,000	35,000	5300	11,000	18,000	33,000	52,000
450		7800	16,000	26,000	43,000	50,000	7900	17,000	29,000	52,000	84,000
600		9500	22,000	34,000	55,000	---	10,000	23,000	40,000	75,000	---
700		11,000	25,000	40,000	61,000	---	12,000	27,000	47,000	90,000	---
800		13,000	30,000	43,000	---	---	14,000	31,000	54,000	---	---
1000		16,000	37,000	50,000	---	---	17,000	39,000	69,000	---	---
1200		20,000	41,000	59,000	---	---	21,000	48,000	83,000	---	---
1500	26,000	53,000	---	---	---	27,000	60,000	---	---	---	
300	(200 to 275 psig spring)	4900	9000	15,000	28,000	42,000	5000	10,000	17,000	30,000	52,000
400		7000	14,000	23,000	40,000	56,000	7100	15,000	25,000	47,000	76,000
500		8500	18,000	29,000	51,000	65,000	8600	19,000	34,000	62,000	103,000
600		9500	22,000	34,000	59,000	---	10,000	23,000	41,000	78,000	---
750		12,500	28,000	44,000	69,000	---	13,000	29,000	51,000	106,000	---
1000		16,000	39,000	58,000	---	---	17,000	40,000	68,000	---	---
1250		21,000	49,000	69,000	---	---	22,000	50,000	87,000	---	---
1500		26,000	59,000	---	---	---	27,000	60,000	---	---	---
300	(200 to 275 psig or 275 to 500 psig spring)	4700	9000	15,000	28,000	39,000	4800	10,000	17,000	29,000	43,000
400		6900	14,000	25,000	40,000	54,000	7000	15,000	26,000	47,000	73,000
525		8600	18,000	35,000	68,000	94,000	9200	20,000	36,000	69,000	112,000
775		11,000	28,000	51,000	95,000	---	12,000	30,000	52,000	112,000	---
1000		16,000	39,000	67,000	---	---	17,000	40,000	68,000	---	---
1275		21,000	50,000	87,000	---	---	22,000	51,000	89,000	---	---
1500		26,000	60,000	---	---	---	26,000	61,000	---	---	---
400		(275 to 500 psig spring)	6600	11,000	16,000	31,000	42,000	7000	13,000	21,000	35,000
550	9700		18,000	23,000	44,000	63,000	9800	20,000	30,000	52,000	78,000
600	9900		19,000	26,000	48,000	---	10,000	21,000	34,000	59,000	---
700	11,000		23,000	30,000	54,000	---	12,000	26,000	40,000	72,000	---
800	13,000		26,000	35,000	61,000	---	14,000	29,000	47,000	81,000	---
900	15,000		29,000	39,000	---	---	16,000	34,000	53,000	---	---
1300	22,000		43,000	58,000	---	---	23,000	50,000	80,000	---	---
1500	26,000		49,000	---	---	---	27,000	58,000	---	---	---

- Continued -

Table 4 (continued). High Pressure Regulator Flow Capacities (scfh of 0.6 Specific Gravity Gas; based on 20% Droop)

Inlet Pressure (PSIG)	Outlet Pressure (PSIG)	Port Diameter										
		1" NPT					2" NPT					
		1/8"	3/16"	1/4"	3/8"	1/2"	1/8"	3/16"	1/4"	3/8"	1/2"	
500	400	8300	16,000	24,000	44,000	62,000	8800	17,000	28,000	49,000	77,000	
650		10,000	24,000	33,000	61,000	86,000	11,000	25,000	40,000	75,000	112,000	
800		13,000	30,000	41,000	76,000	----	14,000	31,000	51,000	95,000	----	
900		15,000	34,000	49,000	85,000	----	16,000	36,000	58,000	110,000	----	
1000		(275 to 500 psig spring)	17,000	38,000	54,000	----	----	18,000	40,000	66,000	----	----
1200	20,000		46,000	63,000	----	----	21,000	48,000	80,000	----	----	
1400	24,000		55,000	76,000	----	----	25,000	57,000	96,000	----	----	
1500	26,000		60,000	----	----	----	27,000	61,000	----	----	----	
550	500	8700	16,000	26,000	50,000	77,000	9000	18,000	30,000	53,000	89,000	
750		12,000	28,000	40,000	78,000	100,000	13,000	29,000	48,000	90,000	141,000	
900		15,000	34,000	52,000	92,000	----	16,000	35,000	60,000	113,000	----	
1000		(275 to 500 psig spring)	17,000	39,000	60,000	100,000	----	18,000	40,000	67,000	130,000	----
1500			26,000	59,000	72,000	----	----	27,000	60,000	82,000	----	----

Regulator Dimensions:

Low-Pressure Regulator, 1" Body

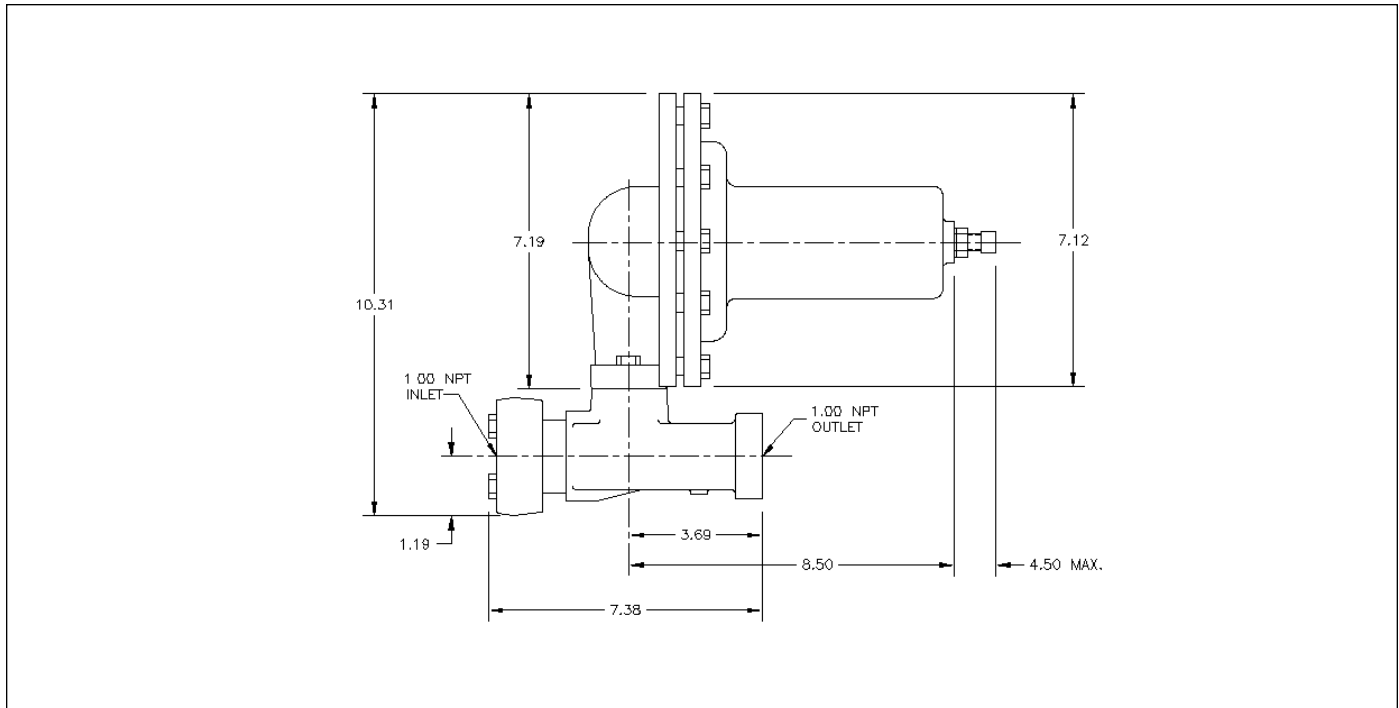

Low-Pressure Regulator, 2" Body

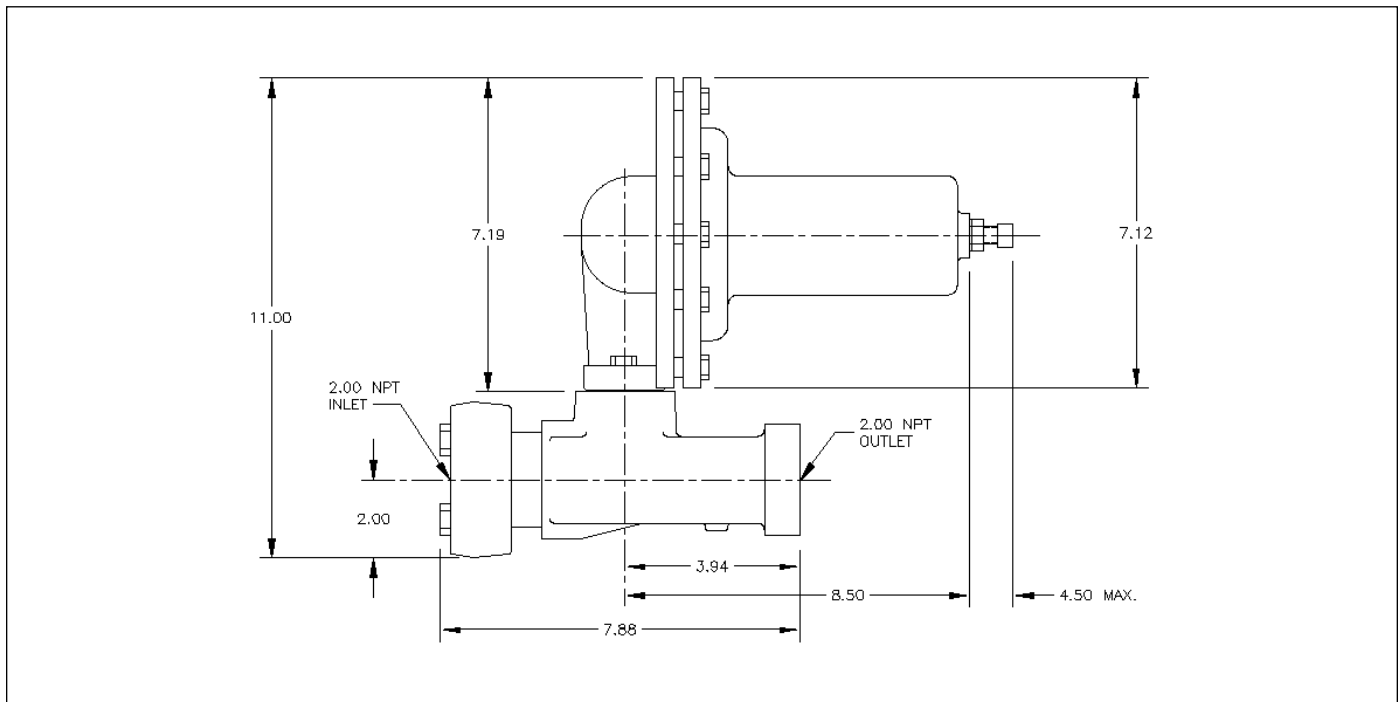

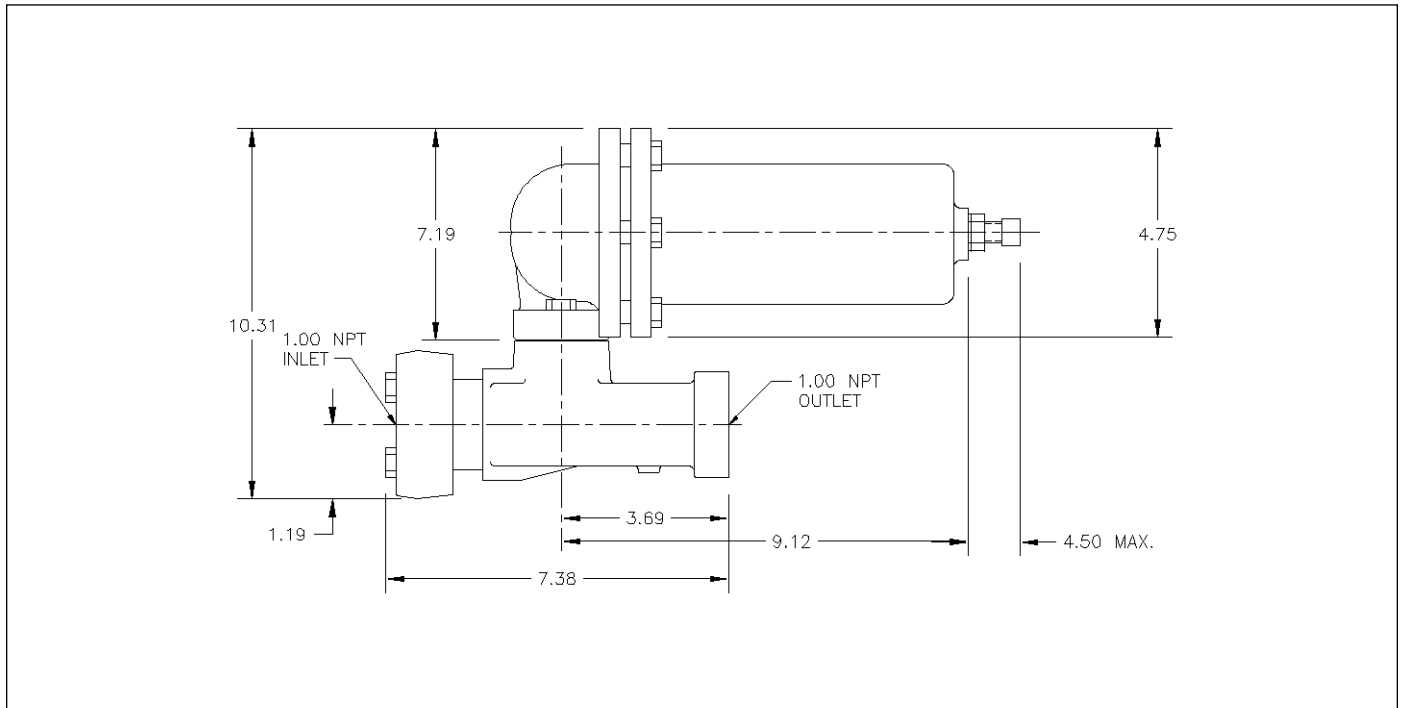
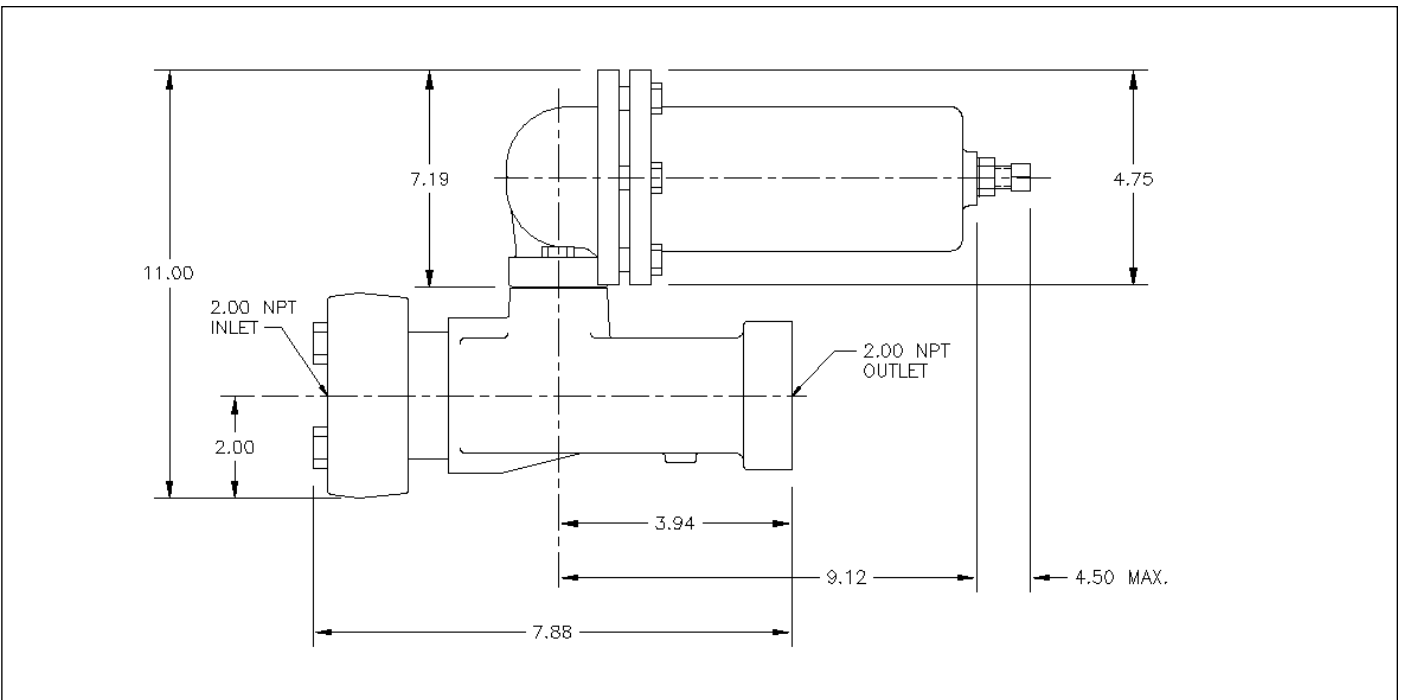
Regulator Dimensions:**High-Pressure Regulator, 1" Body****High-Pressure Regulator, 2" Body**

Model Number Information

Sample Model Number: 5600 - 1 H D G - U 4 S

BODY SIZE	CODE
1"	1
2"	2

STYLE	CODE
Low Pressure (Spring Code A-D only)	L
High Pressure (Spring Code E-K only)	H

BODY MATERIAL	CODE
Ductile Iron	D
WCC Steel	W

OUTLET PRESSURE RANGE	CODE
Low Pressure:	
3 to 10 psig (0.2 to 0.7 bar)	A
8 to 20 psig (0.5 to 1.4 bar)	B
17 to 30 psig (1.2 to 2.0 bar)	C
27 to 40 psig (1.9 to 2.7 bar)	D
High Pressure:	
27 to 50 psig (1.9 to 3.4 bar)	E
46 to 95 psig (3.2 to 6.5 bar)	F
90 to 150 psig (6.2 to 10.3 bar)	G
150 to 200 psig (10.3 to 13.7 bar)	H
200 to 275 psig (13.7 to 18.9 bar)	J
275 to 500 psig (18.9 to 34.5 bar)	K

TRIM MATERIAL	CODE
Brass / TFE (for pressure drops up to 1500 psi)	T
Brass / Nylon (for pressure drops 200-1500 psi)	* U
Brass / Viton (for pressure drops below 200 psi)	V
Stainless Steel / TFE (for pressure drops up to 1500 psi)	W
Stainless Steel / Nylon (for pressure drops 200-1500 psi)	* X
Stainless Steel / Viton (for pressure drops below 200 psi)	Y

PORT DIAMETER	CODE
1/8"	1
1/4"	2
3/8"	3
1/2"	4
3/16"	5

OPTIONS	CODE
None	S
NACE MR-01-75	N

* Nylon is only recommended for use with springs H, J, K.

While this information is presented in good faith and believed to be accurate, Mallard Control Company does not guarantee results based upon such information. Mallard Control Company reserves the right to change the design or specifications of these products without notice.

Mallard Control Company, Inc.

4970 Washington Boulevard
 Beaumont, Texas, USA 77707
 409 842-5392 Phone
 409 842-8165 FAX
www.MallardControl.com