

The Model 5646 Pressure Regulator (Figures 1 and 2) provides economic control of natural gas, air, or a variety of other gases in commercial and industrial applications. This self-operated pressure reducing regulator is equipped with an integral pitot (boost) tube for increased flow capacities and stability. It is designed for inlet pressures up to 1000 psig and outlet pressures from 3 to 200 psig (see Specifications section).

Features:

- **Rugged Construction** - Available with a ductile iron body and aluminum diaphragm case.
- **Easy Maintenance** - Union connection between the diaphragm case and the body allows easy access to trim parts without removing the regulator from the line.
- **Installation Flexibility** - The diaphragm case can be rotated in relation to the regulator body to allow installation in locations with limited space. The regulator may be installed in any position without affecting performance, provided the spring case vent is protected from the elements.
- **Wide Range of Flow Capacities** - A variety of orifice sizes are available to satisfy your flow requirements.
- **Tight Shutoff** - A soft-seat disk, available in nitrile (Buna), fluoroelastomer (Viton), or polyurethane, provides excellent shutoff performance.



Figure 1. Model 5646 Pressure Regulator

Specifications:**Body Size**

3/4"

1"

2"

Orifice Sizes

1/8"

3/16"

1/4"

3/8"

1/2"

Maximum Body Inlet Pressure

1000 psig

Maximum Soft-seat Disk Inlet / Differential Pressure

Polyurethane: 1000 psig / 1000 psid

Buna: 600 psig / 400 psid

Viton: 300 psig / 250 psid

Maximum Inlet / Differential Pressures

See Table 1

Maximum Outlet Pressure (Diaphragm Housing Rating)

See Table 2

Flow Capacities

See Table 3

Flow Coefficients

See Table 4

Operating Temperature Body Size

-20 to 150°F

Materials of Construction

Body:

- Ductile Iron

Spring and Diaphragm Casings:

- Die-cast Aluminum

Diaphragm:

- Nylon-reinforced Buna
- Nomex-reinforced Viton (optional)

O-rings:

- Buna
- Viton (optional)

Orifice:

- Brass
- SST

Disk Holder with Soft-seat Disk:

- Brass with Polyurethane disk
- Brass with Buna disk
- SST with Polyurethane disk
- SST with Buna disk
- SST with Viton disk

Approximate Weight

6.5 lbs.

Dimensions

See Page 7

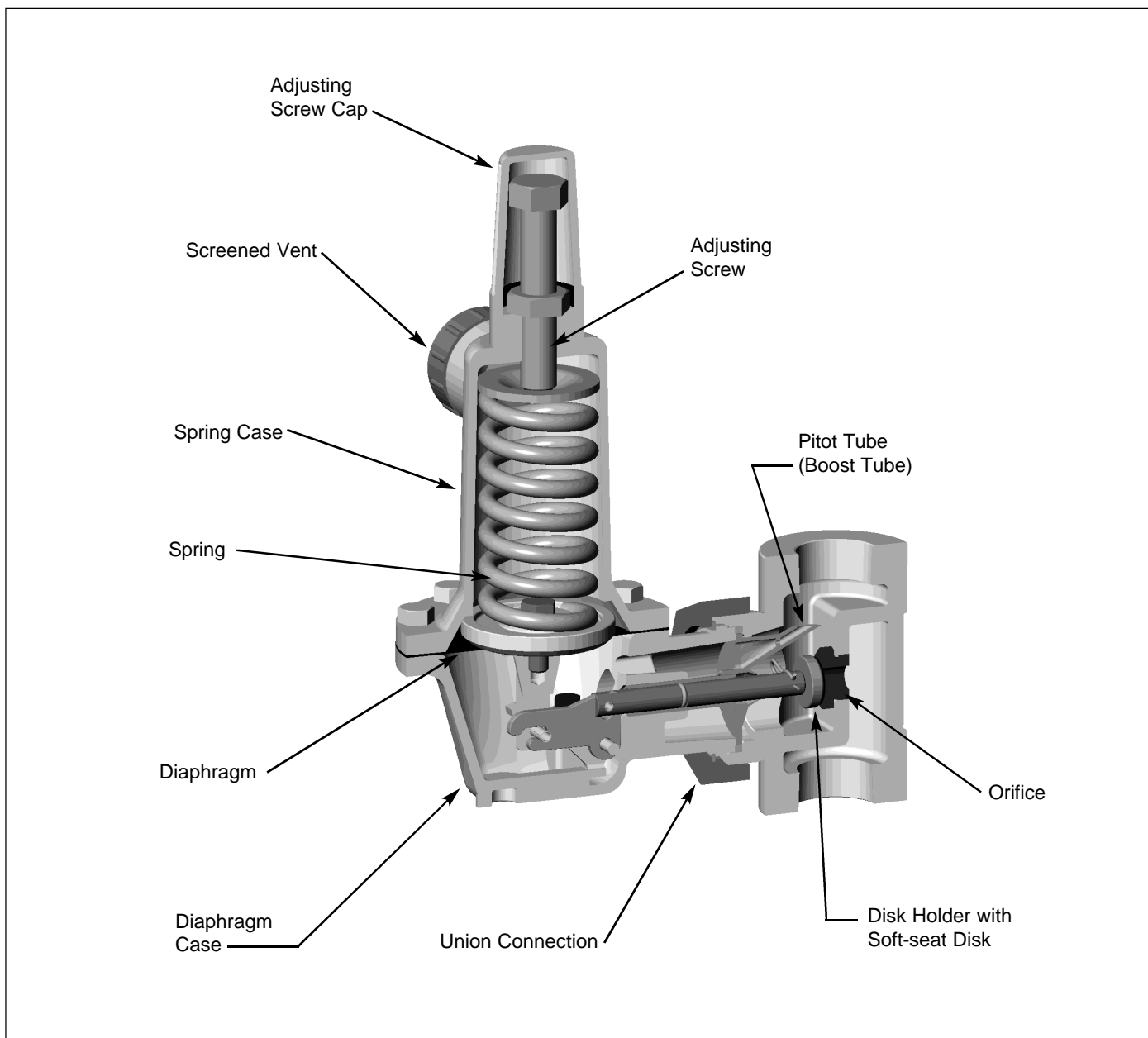

Figure 2. Model 5646 Cross-sectional View

Table 1. Maximum Inlet / Differential Pressures

Spring Range	Orifice	Maximum Inlet Pressure ¹		Maximum Differential Pressure ¹	
		psig	bar	psig	bar
3 to 10 psig	1/8"	125	8.6	125	8.6
	3/16"	125	8.6	125	8.6
	1/4"	125	8.6	125	8.6
	3/8"	125	8.6	125	8.6
	1/2"	100	6.9	100	6.9
8 to 20 psig	1/8"	1000	69.0	1000	69.0
	3/16"	600	41.2	600	41.2
	1/4"	400	27.5	400	27.5
	3/8"	200	13.7	200	13.7
	1/2"	100	6.9	100	6.9
15 to 52 psig	1/8"	1000	69.0	1000	69.0
	3/16"	1000	69.0	1000	69.0
	1/4"	800	55.0	800	55.0
	3/8"	500	34.4	500	34.4
	1/2"	250	17.2	250	17.2
10 to 95 psig	1/8"	1000	69.0	1000	69.0
	3/16"	1000	69.0	1000	69.0
	1/4"	1000	69.0	1000	69.0
	3/8"	600	41.2	600	41.2
	1/2"	350	24.1	350	24.1
50 to 125 psig	1/8"	1000	69.0	1000	69.0
	3/16"	1000	69.0	1000	69.0
	1/4"	1000	69.0	1000	69.0
	3/8"	800	55.0	800	55.0
	1/2"	500	34.4	500	34.4
100 to 200 psig	1/8"	1000	69.0	1000	69.0
	3/16"	1000	69.0	1000	69.0
	1/4"	1000	69.0	1000	69.0
	3/8"	1000	69.0	800	55.0
	1/2"	750	51.5	500	34.4

1. Refer to page 2 for maximum body and disk pressure specifications.

Table 2. Maximum Outlet Pressure

Criteria	Maximum Pressure	
	psig	bar
Maximum outlet pressure over pressure setting to prevent damage to internal parts	100	6.9
Maximum outlet pressure to prevent leak to atmosphere (damage to internal parts may occur)	250	17.2
Maximum outlet pressure to prevent burst of diaphragm housing (leak to atmosphere and damage to internal parts may occur)	400	27.5

Overpressure Protection

The Model 5646 Regulator's outlet pressure rating is lower than its inlet pressure rating. Consequently, overpressure protection is required if the actual inlet pressure of a given application can exceed the regulator's outlet pressure rating. To avoid overpressure, the user must provide an appropriate pressure relieving or pressure limiting device to ensure that none of the limits shown in Table 2 are exceeded.

Capacity Information

Natural gas regulating capacities are given in Table 3 for selected inlet / outlet pressures. Flows are in scfh (60°F / 14.7 psia) of 0.6 SG natural gas. To determine the equivalent regulating capacities of other gases, multiply

the capacity given in Table 3 by 0.775, and divide by the square root of the appropriate specific gravity.

If capacity is desired in normal cubic meters per hour, multiply the scfh capacity given in Table 3 by 0.0268.

Table 3. Flow Capacities, scfh of 0.6 specific gravity gas; based on 20% droop

Outlet Pressure Range (PSIG)	Inlet Pressure (PSIG)	Outlet Pressure (PSIG)	Port Diameter													
			All Body Sizes	3/4" Body					1" Body				2" Body			
				1/8"	3/16"	1/4"	3/8"	1/2"	3/16"	1/4"	3/8"	1/2"	3/16"	1/4"	3/8"	1/2"
3-10 psi Yellow Spring	10	5	325	680	1120	1620	1940	730	1160	1980	2520	730	1160	1980	2520	
	15		450	860	1340	2200	3410	910	1540	2560	5000	910	1540	2560	5000	
	20		540	1200	1850	3100	4400	1230	2100	3450	6900	1230	2100	3450	6900	
	30		690	1570	2600	3930	6890	1610	2900	4850	11250	1610	2900	4850	11250	
	50		1000	2480	4000	6180	7280	2550	4500	8000	13500	2550	4500	8000	13500	
	75		1400	3000	5100	6670	7750	3130	5750	9770	14600	3130	5750	9770	14600	
10-95 psi Dark Green Spring	100	10	180	270	360	520	700	270	360	520	700	270	360	520	700	
	150		240	350	460	690	920	350	460	690	920	350	460	690	920	
	200		280	410	550	820	1090	410	550	820	1090	410	550	820	1090	
	300		460	680	910	1350	1800	680	910	1350	1800	680	910	1350	1800	
	500		630	950	1270	1870	2490	950	1270	1870	2500	950	1270	1870	2500	
	100		810	1210	1620	2390	3190	1210	1620	2390	3200	1210	1620	2390	3200	
	150		1160	1740	2330	3430	-	1740	2330	3430	-	1740	2330	3430	-	
	200		1520	2270	3040	4480	-	2270	3040	4480	-	2270	3040	4480	-	
	300		2230	3330	4450	6570	-	3330	4450	6570	-	3330	4450	6570	-	
	500		3640	5450	7290	-	-	5450	7290	-	-	5450	7290	-	-	
8-20 psi Aluminum Spring	20	15	450	950	1480	2730	3480	950	1480	2950	5100	950	1480	2950	5100	
	30		660	1440	2530	4400	5050	1440	2530	4800	7480	1440	2530	4800	7480	
	50		1000	2480	4050	5300	7500	2480	4200	7700	11500	2480	4200	7700	11500	
	75		1400	3000	4900	6850	10000	3000	5400	10700	16300	3000	5400	10700	16300	
	100		1800	3800	6050	8800	11000	3800	7850	14200	18500	3800	7850	14200	18500	
	150		2600	5800	8500	11000	-	5800	11500	18000	-	5800	11500	18000	-	
	200	3300	7350	9700	12500	-	7350	14300	22200	-	7350	14300	22200	-		
	400	6100	13700	12400	-	-	14800	24500	-	-	14800	24500	-	-		
	600	9070	14500	-	-	-	21000	-	-	-	21000	-	-	-		
	750	11500	-	-	-	-	-	-	-	-	-	-	-	-		
	1000	15500	-	-	-	-	-	-	-	-	-	-	-	-		
	30	20	640	1430	2500	4250	5900	1430	2500	4600	7280	1430	2500	4600	7280	
	50		1000	2250	4000	6810	8500	2320	4000	7800	11300	2320	4000	7800	11300	
	75		1400	3000	5100	8200	11000	3000	5400	10700	16300	3000	5400	10700	16300	
100	1800		3800	6750	10400	12500	3800	7850	14800	18500	3800	7850	14800	18500		
150	2600		5800	8800	12800	-	5800	11500	20500	-	5800	11500	20500	-		
200	3300		7350	10000	15200	-	7350	14300	25200	-	7350	14300	25200	-		
400	6100		13700	14200	-	-	14800	24500	-	-	14800	24500	-	-		
600	9070		14500	-	-	-	21000	-	-	-	21000	-	-	-		
750	11500		-	-	-	-	-	-	-	-	-	-	-	-		
1000	15500		-	-	-	-	-	-	-	-	-	-	-	-		
30	25		580	1000	1300	1950	2600	1000	1300	1950	2600	1000	1300	1950	2600	
50			1000	1700	2300	3350	4500	1700	2300	3350	4500	1700	2300	3350	4500	
75			1400	2350	3150	4650	6250	2350	3150	4650	6250	2350	3150	4650	6250	
100			1000	3050	4050	5950	8000	3050	4050	5950	8000	3050	4050	5950	8000	
150		2600	4350	5800	8600	-	4350	5800	8600	-	4350	5800	8600	-		
200		3300	5700	7600	11200	-	5700	7600	11200	-	5700	7600	11200	-		
300		4800	8300	11150	16400	-	8300	11150	16400	-	8300	11150	16400	-		
400		6400	10950	14700	-	-	10900	14700	-	-	10900	14700	-	-		
500		8000	13600	18200	-	-	13600	18200	-	-	13600	18200	-	-		
750		11500	20000	-	-	-	20250	-	-	-	20250	-	-	-		
1000		15500	25000	-	-	-	26850	-	-	-	26850	-	-	-		

-Continued-

Table 3. Flow Capacities, scfh of 0.6 specific gravity gas; based on 20% droop (Continued)

Outlet Pressure Range (PSIG)	Inlet Pressure (PSIG)	Outlet Pressure (PSIG)	Port Diameter													
			All Body Sizes	3/4" Body					1" Body				2" Body			
				1/8"	3/16"	1/4"	3/8"	1/2"	3/16"	1/4"	3/8"	1/2"	3/16"	1/4"	3/8"	1/2"
15-52 psi White Spring	40	30	780	1620	2800	4400	5400	1620	2800	4400	5800	1620	2800	4400	5800	
	50		950	2100	3700	5600	7000	2100	3700	5600	7700	2100	3700	5600	7700	
	75		1400	3000	5000	8000	8950	3000	5000	8600	11400	3000	5000	8600	11400	
	100		1800	3800	7250	9200	11000	3800	7250	10700	16000	3800	7250	10700	16000	
	150		2600	5800	10500	12800	16000	5800	10500	16500	23000	5800	10500	16500	23000	
	200		3300	7350	12300	16000	18000	7350	12800	21000	29000	7350	12800	21000	29000	
	300		4800	10800	15000	19000	-	10800	17800	26000	-	10800	17800	26000	-	
	400		6500	13700	19000	21000	-	13700	23000	28000	-	13700	23000	28000	-	
	750		11500	22000	21200	-	-	23400	30300	-	-	23400	30300	-	-	
	1000		15500	23000	-	-	-	31000	-	-	-	31000	-	-	-	
	50	40	900	2000	3400	5500	6900	2000	3400	5500	7100	2000	3400	5500	7100	
	75		1400	3000	5000	8000	8950	3000	5000	8200	10300	3000	5000	8200	10300	
	100		1800	3800	7250	9200	11000	3800	7250	10700	16000	3800	7250	10700	16000	
	150		2600	5800	10500	12800	16800	5800	10500	16500	25000	5800	10500	16500	25000	
	200		3300	7350	12300	16000	21000	7350	12800	22000	33000	7350	12800	22000	33000	
	300		4800	10800	15000	19800	-	10800	17800	28000	-	10800	17800	28000	-	
	400		6500	13700	19000	23000	-	13700	23000	32000	-	13700	23000	32000	-	
	750		11500	22500	24400	-	-	25400	34300	-	-	25400	34300	-	-	
	1000		15500	24000	-	-	-	34000	-	-	-	34000	-	-	-	
	60		50	1020	2100	3900	6300	8600	2100	3900	6300	9000	2100	3900	6300	9000
	75	1350		2900	5200	8900	12500	2900	5200	8900	13500	2900	5200	8900	13500	
	100	1760		3750	6900	11500	15000	3750	6900	12500	16800	3750	6900	12500	16800	
	150	2600		5800	10500	15300	23000	5800	10500	19000	33400	5800	10500	19000	33400	
	200	3300		7350	12300	19000	27400	7350	12300	24000	42500	7350	12300	24000	42500	
300	4800	10800		17500	26000	-	10800	19000	33000	-	10800	19000	33000	-		
400	6500	13700		20000	27500	-	13700	25000	46000	-	13700	25000	46000	-		
750	11500	22500		28000	-	-	25400	43400	-	-	25400	43400	-	-		
1000	15500	24000		-	-	-	34000	-	-	-	34000	-	-	-		
80	75	1190		2300	3450	5000	6250	2300	3450	5000	6250	2300	3450	5000	6250	
90		1450	2900	4250	6300	7100	2900	4250	6300	7100	2900	4250	6300	7100		
100		1680	3450	4900	7600	8050	3450	4900	7600	8050	3450	4900	7600	8050		
150		2500	5400	7300	12000	-	5400	7300	12000	-	5400	7300	12000	-		
200		3300	7100	9700	15700	-	7100	9700	15700	-	7100	9700	15700	-		
300		4800	10400	14200	20450	-	10400	14200	20450	-	10400	14200	20450	-		
400		6400	13700	18700	-	-	13700	18700	-	-	13700	18700	-	-		
500		8000	17000	23000	-	-	17000	23000	-	-	17000	23000	-	-		
750		11500	25000	-	-	-	25000	-	-	-	25000	-	-	-		
1000		15500	29000	-	-	-	34000	-	-	-	29000	-	-	-		
50-125psi Tan Spring	110	100	1640	3500	5900	7900	9300	3500	5900	7900	9300	3500	5900	7900	9300	
	125		2000	4400	7300	12000	14500	4400	7300	12000	14500	4400	7300	12000	14500	
	150		2500	5500	9000	16000	20500	5500	9000	16000	23500	5500	9000	16000	23500	
	200		3300	7000	12000	21000	25600	7000	12000	21000	34600	7000	12000	21000	34600	
	300		4800	10500	18000	30000	32000	10500	18000	30100	51000	10500	18000	30100	51000	
	400	6400	13700	25000	34500	36000	13700	25000	44500	70000	13700	25000	44500	70000		
	500	8040	17200	32000	38500	39200	17200	32000	66000	84000	17200	32000	66000	84000		
	800	12100	26500	36000	39500	-	30000	44000	89000	-	30000	44000	89000	-		
	1000	15500	29000	38000	-	-	36000	57000	-	-	36000	57000	-	-		
	135	125	1960	4200	7600	11500	13900	4200	7600	11500	13900	4200	7600	11500	13900	
	150		2340	5000	8900	15700	20000	5000	8900	15700	20000	5000	8900	15700	20000	
	200		3300	7000	12800	22200	28500	7000	13100	26000	32500	7000	13100	26000	32500	
	300		4800	10500	19000	32500	38000	10500	19400	38000	52000	10500	19400	38000	52000	
	400		6400	13700	26000	37500	47000	13700	26400	51000	90000	13700	26400	51000	90000	
	500	8040	17200	33000	42500	51000	17200	33400	68000	105000	17200	33400	68000	105000		
	800	12100	26500	46000	50000	-	30000	46500	99000	-	30000	46500	99000	-		
1000	15500	29000	48000	-	-	36000	63000	-	-	36000	63000	-	-			

Table 3. Flow Capacities, scfh of 0.6 specific gravity gas; based on 20% droop (Continued)

Outlet Pressure Range (PSIG)	Inlet Pressure (PSIG)	Outlet Pressure (PSIG)	Port Diameter												
			All Body Sizes	3/4" Body				1" Body				2" Body			
				1/8"	3/16"	1/4"	3/8"	1/2"	3/16"	1/4"	3/8"	1/2"	3/16"	1/4"	3/8"
100-200 psi Grey Spring	200	150	2900	7150	11000	21200	30500	7150	11000	21200	30500	7150	11000	21200	30500
	300		4600	11100	19000	31200	45000	11100	19000	31200	45000	11100	19000	31200	45000
	400		6400	14800	24500	39500	50000	14800	24800	39500	50000	14800	24800	39500	50000
	500		8150	18000	29500	50500	52000	18000	32000	50500	52000	18000	32000	50500	52000
	750		12000	27000	43000	52500	-	27000	45000	52500	-	27000	45000	52500	-
	1000		15200	35500	55000	-	-	35500	58000	-	-	35500	58000	-	-
	250	200	3800	8250	15000	30500	40000	8250	15000	30500	40000	8250	15000	30500	40000
	300		4600	11100	19200	35500	52000	11100	19200	35500	52000	11100	19200	35500	52000
	400		6400	14800	25300	52000	65000	14800	27000	52000	65000	14800	27000	52000	65000
	500		8150	18000	30800	60000	68000	18000	33000	60000	68000	18000	33000	60000	68000
750	12000		27000	45000	62000	-	27000	49000	62000	-	27000	49000	62000	-	
1000	15200		35500	58000	-	-	35500	63000	-	-	35500	63000	-	-	

Table 4. Flow Coefficients

Port Diameter	Flow Coefficient (C _v)		
	3/4" Body	1" Body	2" Body
1/8"	0.43	0.43	0.43
3/16"	1.00	1.00	1.00
1/4"	1.60	1.70	1.70
3/8"	2.95	3.40	3.40
1/2"	4.85	5.30	5.30

Dimensions

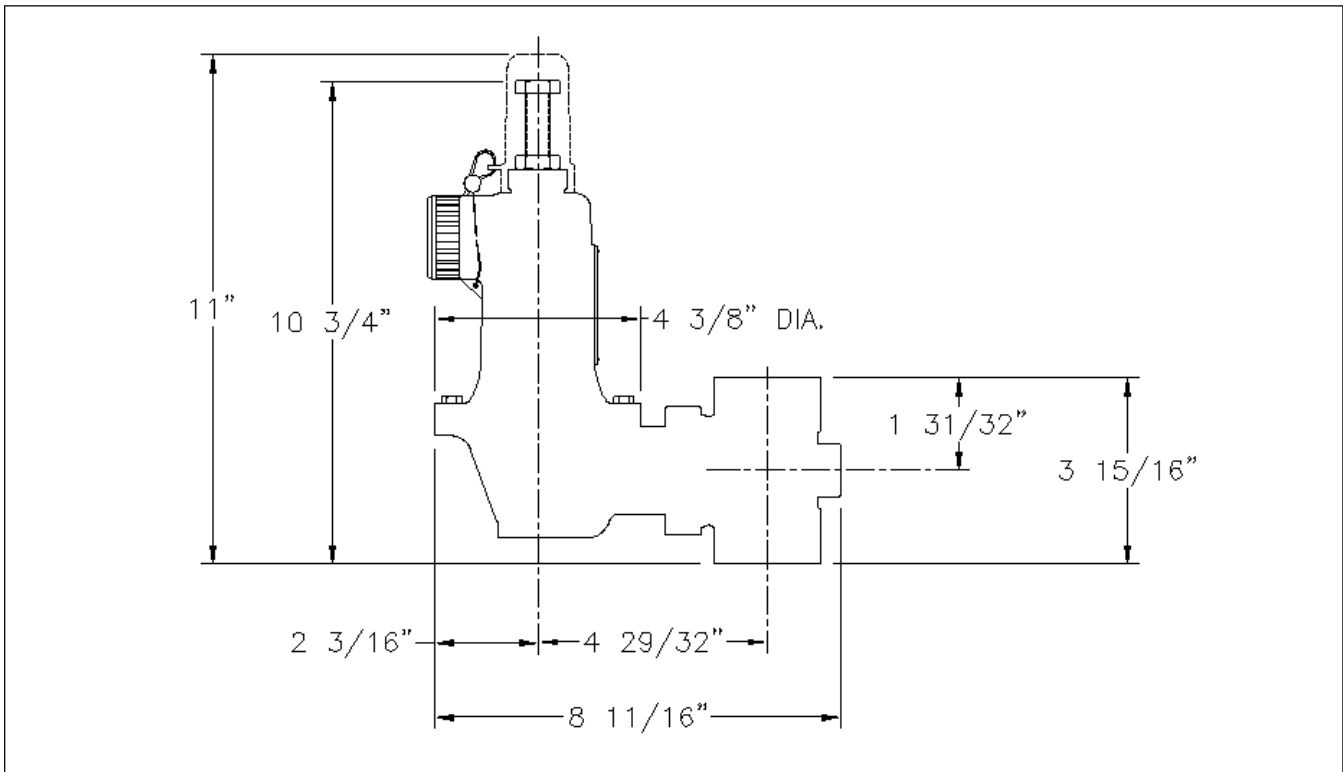

Model Number Information

Sample Model Number: 5646B - 1 D C - B 4 S

BODY SIZE	CODE
3/4"	3
1"	1
2"	2

BODY MATERIAL	CODE
Ductile Iron	D

OUTLET PRESSURE	CODE
3 to 10 psig	A
8 to 20 psig	B
15 to 52 psig	C
10 to 95 psig	D
50 to 125 psig	E
100 to 200 psig	F

TRIM MATERIAL	CODE
Brass / Polyurethane	P
Brass / Buna	B
Stainless Steel / Polyurethane	U
Stainless Steel / Buna	S
Stainless Steel / Viton	V

PORT DIAMETER	CODE
1/8"	2
3/16"	3
1/4"	4
3/8"	6
1/2"	8

OPTIONS	CODE
None	S
Viton Seals and Diaphragm	V

While this information is presented in good faith and believed to be accurate, Mallard Control Company does not guarantee results based upon such information. Mallard Control Company reserves the right to change the design or specifications of these products without notice.

Mallard Control Company, Inc.

4970 Washington Boulevard
 Beaumont, Texas, USA 77707
 409 842-5392 Phone
 409 842-8165 FAX
 www.MallardControl.com