

The Model 5800 Piston Check Valve is made for the prevention of gas or liquid backflow. Some common applications for this valve are gas and liquid pipelines, air or gas compressors, production leases, or safety systems. The variety of end connection styles makes the piston check valve adaptable to almost any application.

Features:

- **Non-slamming Piston** - A check assembly working in conjunction with an orifice plug installed into the piston helps to prevent "slamming" of the piston into the valve seat.
- **Simple Maintenance** - The Model 5800 valve internals simply lift out once the bonnet has been removed. The seat design makes it simple to remove or install without the hassle of screw threads or having the seat machined integral to the body.
- **Smooth Opening** - A self-lubricating piston seal and quality workmanship combine for smooth, consistent operation.
- **NACE MR-01-75** - Optional materials of construction are available that comply with NACE MR-01-75 specifications for sour gas applications.



Specifications:**Available Body Sizes**

2"
3"
4"
6"

End Connections / Pressure Ratings¹

FNPT	3750 psig (259 bar)
150# RF	290 psig (20 bar)
300# RF	750 psig (52 bar)
600# RF	1500 psig (103 bar)
600# RTJ	1500 psig (103 bar)
900# RF	2250 psig (155 bar)
900# RTJ	2250 psig (155 bar)
1500# RF	3750 psig (259 bar)
1500# RTJ	3750 psig (259 bar)

Temperature Limits

-20° to 450° F (-29° to 232° C)

Maximum Flow Coefficients

2" Body:	70 C _v
3" Body:	128 C _v
4" Body:	198 C _v
6" Body:	

Materials of Construction (Std Configuration*)

Body	ASTM A216 WCC C.S.
Bonnet	ASTM A516 Gr.70 C.S.
Body Studs	ASTM A193 Gr. B7
Stud Nuts	ASTM A194 Gr. 2H
Pipe Plug	ASTM A105 C.S.

Internals:

Plug	316 SST
Plug Insert (optional)	TFE or Carbide
Seat	316 SST
Cage	17-4Ph SST H1150M
Guide	316 SST
Spring	316 SST
Ball Check Assembly	316 SST
Orifice Plug	316 SST
Piston Seal	PTFE / Elgiloy
Gaskets	304SST / Grafoil Inconel / Grafoil (NACE)
Lifting Screw	SST

(1) Maximum pressure ratings @ 100°F (38°C)

Approximate Shipping Weights, Pounds

End Connections						
Valve Size	NPT	150# Flg	300# Flg	600# Flg	900# Flg	1500# Flg
2"	80	86	102	115	126	137
3"	N/A	125	135	138	162	252
4"	N/A	205	215	226	257	409
6"	N/A	305	347	425	N/A	N/A

Approximate Shipping Weights, Kg

End Connections						
Valve Size	NPT	150# Flg	300# Flg	600# Flg	900# Flg	1500# Flg
2"	36	39	46	52	57	62
3"	N/A	57	61	63	73	114
4"	N/A	93	98	103	117	186
6"	N/A	139	158	193	N/A	N/A

Check Valve Dimensions (Inches)

Body End Connection Style	2"			3"			4"			6"		
	"A"	"B" Max.	"C" Max.	"A"	"B" Max.	"C" Max.	"A"	"B" Max.	"C" Max.	"A"	"B" Max.	"C" Max.
FNPT	11.25	4.38	12.12	N/A	6.25	16.88	N/A	7.50	19.38	N/A	7.15	17.87
BWE	11.25			9.62			10.88					
SWE	11.25			*			*					
150# RF	10.00			11.75			13.88					
150# RTJ	10.50			12.25			14.38					
300# RF	10.50			12.50			14.50					
300# RTJ	11.12			13.12			15.12					
600# RF	11.25			13.25			15.50					
600#RTJ	11.38			13.38			15.62					
900# RF	14.75			15.50			17.00					
900# RTJ	14.88			15.62			17.12					
1500# RF	14.75			18.12			20.88					
1500# RTJ	14.88			18.25			21.00					

* Consult Factory

Check Valve Dimensions (mm)

Body End Connection Style	2"			3"			4"			6"		
	"A"	"B" Max.	"C" Max.	"A"	"B" Max.	"C" Max.	"A"	"B" Max.	"C" Max.	"A"	"B" Max.	"C" Max.
FNPT	286	111	308	N/A	159	428	N/A	190	492	N/A	181	454
BWE	286			244			276					
SWE	286			*			*					
150# RF	254			298			352					
150# RTJ	266			311			365					
300# RF	266			317			368					
300# RTJ	282			333			384					
600# RF	286			336			393					
600#RTJ	289			339			397					
900# RF	374			393			431					
900# RTJ	378			397			435					
1500# RF	374			460			530					
1500# RTJ	378			463			533					

* Consult Factory

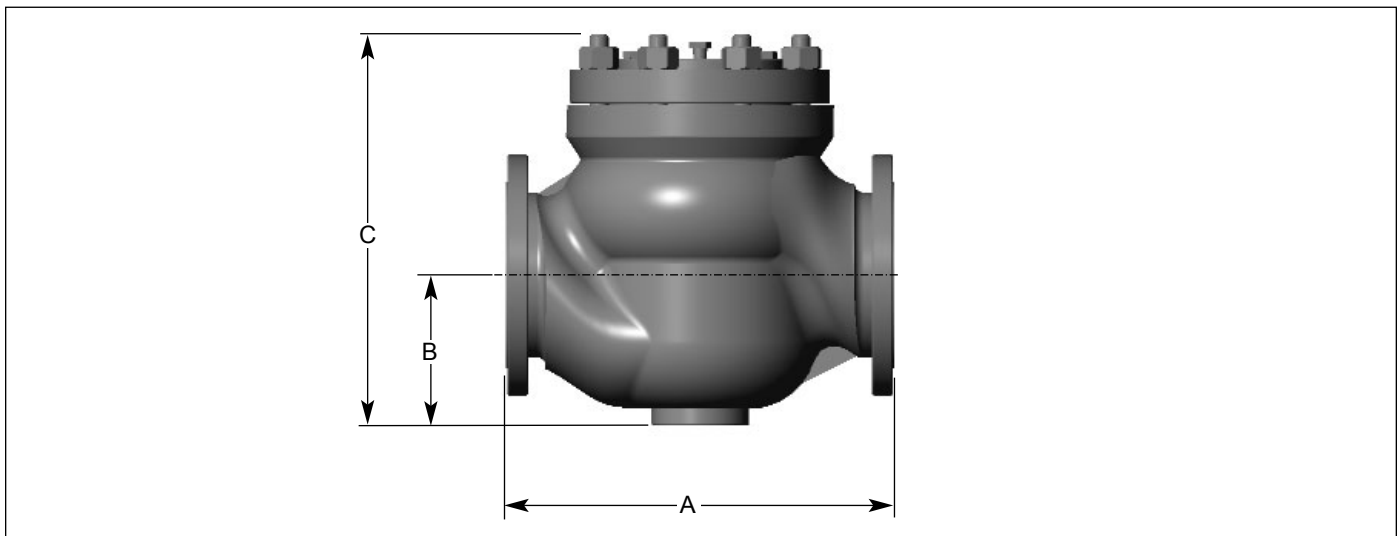

Model Number Information

Sample Model Number: 5800 - **2 F 6 - G S - 3 S G**

BODY SIZE		CODE
2"		2
3"		3
4"		4
6"		6

END CONNECTIONS		CODE
Female NPT		S
Raised Face (RF) Flange		F
Ring Type Joint (RTJ) Flange		J

ANSI CLASS (PRESSURE RATING)		CODE
150 (275 psig)		1
300 (740 psig)		3
600 (1480 psig)		6
900 (2220 psig)		9
1500 (3750 psig)		5

MATERIALS OF CONSTRUCTION		CODE
Carbon Steel - Standard Service		-
Carbon Steel - NACE MR-01-75		N

BODY STYLE		CODE
Globe		G
Globe with Drain		D

LOAD SPRING / GASKETS		CODE
316 SST - Spring / 304/Grf Gaskets		S
Inconel - Spring / Inc/Grf Gaskets		N

SPECIAL BODY CONFIGURATION		CODE
Mllard F - F (ANSI Control Valve) ISA S75.03, S75.16		-
Other - Non-Standard F-F, to be specified on order		X

TRIM MATERIAL		CODE
Tungsten Carbide		2
316 Stainless Steel		3
316 Stainless Steel with TFE/EG Plug Insert		8

PISTON SEAL		CODE
TFE/Elgiloy Spring Energized		S
Other		X

SERVICE APPLICATION		CODE
Gas		G
Liquid		L

While this information is presented in good faith and believed to be accurate, Mallard Control Company does not guarantee results based upon such information. Mallard Control Company reserves the right to change the design or specifications of these products without notice.

Mallard Control Company, Inc.

4970 Washington Boulevard
 Beaumont, Texas, USA 77707
 409 842-5392 Phone
 409 842-8165 FAX
 www.MallardControl.com